

field:

a free journal for architecture

PRINT ISSN: 2753-3638

ONLINE ISSN: 1755-0068

www.field-journal.org

vol.9(1)

DOWN IN MEXICO: TRANSMIGRATION AND STORYING AT THE BORDER.

Luis Hernan

ABSTRACT

New technologies on the Mexico-United States border involve an unprecedented collaboration between Silicon Valley and the United States Department of Defence. They bring with them a new form of narrating the border itself which, drawing on Science Fiction and Fantasy, is a means of justifying increasingly cruel ways of policing it.

Crossing the border is often a transmigration, suggesting a change of racial states that involve moving from a darker to a whiter shade. In this article, I experiment with a transmigration of stories, moving across different traditions of imagining the future. My ficto-critical approach is inspired by Magical Realism as a way to enable a dual spatiality of the text. It allows for Western and Native understandings of the land to co-exist and is a strategy to explore the connections between the imaginary and the real. The fragmentation, and the splicing involved in bringing them together, is a methodology that makes visible the project of colonisation and violence that are made invisible by the new technologies of the border.

To claim that something is true is now the convention of every made-up story.¹

INTRODUCTION

The best thing to do will be to traverse the border (invent and traverse it).² The crossing is a transmigration, a change of states; a process of becoming, a transmutation of sorts, going from a darker to a lighter shade. The border I am imagining is real – it is made of steel plates and bollards, fencing and barbed wire. The border is an unforgiving landscape that kills thousands every year; a hostile immigration system that hunts 'wetbacks.'³ And yet it needs to be imagined, storied. The materiality of the border has been brought together by ideas and discourses of what a division line between two countries, Mexico and the United States of America, means. I wonder, how am I meant to story this border? ¿Cómo hago sentido de esta frontera? This border, esta frontera en especial.

I started writing about the Mexico-United States border in 2019, the midway point of Donald J. Trump's tenure as the 45th president of the United States and a moment when doing so had an urgency: with a need to make sense of the way the border had been weaponised in a presidential campaign, a common occurrence in American politics but, this time, likely a deciding factor in a bitterly fought election.⁴ Writing about the border was motivated by my own story as a migrant. I first crossed the border, physically, when I was four years old and since then

I have repeated the crossing, the transmigration, symbolically.⁵ I write this piece after having lived in the United Kingdom for more than a decade. My life story so far – studying in prestigious, private universities in Mexico, with my postgraduate study abroad hastening my becoming a part of the English-speaking academia – follows the script of 'whitening'.⁶ Growing up I was racialised white, despite having a father who was racialised brown, and these rites of passage have, symbolically, made me whiter, more cosmopolitan, modern, less indigenous. The Mexico-United States border weighs heavily on my own sense of identity and so I must imagine and story it.

In *Tell Me How It Ends: An Essay in Forty Questions*, Valeria Luiselli reflects on the experience of volunteering as a translator for refugee children.⁷ To her, the practice of translation is beyond interpreting and more a fundamental act of turning reality into narrative: 'The children's stories are always shuffled, stuttered, always shattered beyond the repair of a narrative order. The problem with trying to tell their story is that it has no beginning, no middle, and no end.'⁸ The experience of Luiselli is representative of the border itself: to narrate the borderlands is to string together stories that do not make sense, stories that are shuffled and shattered in multiple imaginations and memories. These contested stories and mythologies are important as, once more, they are at the centre of American politics. As the Democratic and Republican parties prepare for their caucuses and primary elections, the border with Mexico is once again at the core of the political debate with pre-candidates, including Donald Trump, promising tougher

1 Jorge Luis Borges, N.T. Di Giovanni, and A. Reid, *The Book of Sand*, Penguin Book (New York: Penguin Books, 1979).

2 A playful rephrasing of the opening lines of Octavio Paz's *The Monkey Grammarian*. Paz is an important piece in understanding the stories of the border and the Mexican Diaspora, as explored later in this text. See: Octavio Paz, *The Monkey Grammarian* (London: Peter Owen, 1989).

3 Ivar Chara López suggests that the 'smart' technologies of the border date back to at least the 1970s with the development of the Border Patrol intrusion detection system. The idea of securing the border through sensing technologies was inspired by emerging theories of Cybernetics and shaped by a racialised understanding of bodies. Popular press at the time reported that the new technologies would 'help agents control wetbacks and narcotic smugglers'. Wetback is a racist epithet which makes reference to migrants crossing 'illegally' by swimming across the Rio Bravo. See: Iván Chara-López, 'Sensing Intruders: Race and the Automation of Border Control', *American Quarterly*, 71.2 (2019), pp. 495–518, <https://doi.org/10.1353/aq.2019.0040>.

4 The work I started in 2019 would be later published as: Luis Hernan, 'Wireless Borders: Illegal Bodies and Connected Futures', in *Informal Settlements of the Global South, Architectural Borders and Territories*, 1st edn (London: Routledge, 2023), pp. 47–62.

immigration policies that involve a more secure border. Separating the 2016 and 2024 elections are a new set of stories, told in a familiar register, that have shifted the symbolic and material articulation of the border.

I have written elsewhere of the way that Silicon Valley has become involved in the militarisation of the border, creating technologies of surveillance and deterrence that are meant to ‘leverage’ consumer technology in the defence of the American nation.⁹ Overall, I am interested in Silicon Valley cultures increasingly defining architectural spaces and how, in turn, these cultures were shaped by the bringing together of mythologies and imaginations that draw heavily from Science Fiction (SF).¹⁰ SF has become crucial in the efforts to militarise the border, reconfiguring new imaginaries of masculinity and right-wing politics which in turn frame the new technologies of the border as being used for the right cause, defending the nation from the threats that lay beyond the realm.

The border has always been a fertile ground for stories – fictional or other – which define the American nation as a grand march of progress westwards, expanding the domain of civilisation and shrinking that of the unruly and the untamed. This foundational myth makes invisible the other processes of movement, relocation and expulsion that have informed the communities who live within its (shifting) borders and which, spatially, are defined by a movement from South to North.¹¹ In this article, I experiment with mythologies that counter the new Silicon Valley technological materialities of the border, technologies that make crossing more dangerous while simultaneously shifting politics and ethical framing by appealing to a new demographic of gamers and SF fans who are called

to defend the realm from an ‘alien’ invasion. Central to understanding these new mythologies is the figure of the ‘tech-bro’, a man who styles himself as the genius behind Silicon Valley and who constructs his persona through a performative display of masculinity, bluster and expletive-laden comebacks (occasionally escalating to challenges to bare-knuckle cage-fights).

I attempt here a transmigration of stories, weaving fiction and drawing, to guide me in a voyage that starts in the new mythologies of the border, as (re)imagined by Silicon Valley. On the other side of this journey are counter mythologies suggesting different processes of movement, displacement and becoming in and around the Mexico-United States border. My starting point is Palmer Luckey, the founder of Anduril and creator of the Sentry. I analyse his own use of Science Fiction to narrate the technology and shift its politics towards an audience of *The Lord of the Rings* fans. I then shift my focus to Magical Realism and the way its dual spatiality allows for two conflicting world views to be co-present in the text, the logic of the European intellectual tradition and the mysterious, magical (and often assumed irrational) native world system. Inspired by the politics of the possible enabled by Magical Realism, in the second part of the paper I use a ficto-critical approach, weaving fictional and critical accounts in three transmigrated stories: Dressing Up, Categories of Exclusion, and Stories of the Border. ‘America’ is actually the name of the whole continent, but for the sake of consistency with existing literature I use ‘America’ as a short name for the United States of America.

5 This piece is, in many ways, one half of a longer piece. I suggest reading this piece in combination with: Luis Hernan, ‘Of Force Fields and Men: Fiction and Race in the Mexican Border’, *Architecture and Culture, Border Fictions*, Special Issue, 9.2 (2024).

6 The notion of blanquitud or whitening was proposed by the Ecuadorian-Mexican philosopher Bolívar Echeverría to theorise the role of race in the project of Modernity, especially as it involves the processes of colonisation and extractivism that have defined Latin-America. The sense in which I use it here, as a personal process of “betterment” is developed further by Federico Navarrete. See: Bolívar Echeverría, *Modernity and ‘Whiteness’*, trans. by Rodrigo Ferreira (Cambridge: Polity Press, 2019); Federico Navarrete Linares, ‘Blanquitud vs. blancaura, mestizaje y privilegio en México de los siglos XIX a XXI, una propuesta de interpretación’, *Estudios Sociológicos de El Colegio de México*, 40 (2022), pp. 119–50, <https://doi.org/10.24201/es.2022v40.2080>.

7 Valeria Luiselli, *Tell Me How It Ends: An Essay in Forty Questions* (London: Harper Collins, 2017).

8 Luiselli, *Tell Me*, p. 14.

9 Hernan, ‘Of Force Fields’.

10 Luis Hernan and Carolina Ramirez-Figueroa, ‘A Home with a Future. Digital Domesticity and the Vague Fictions of Silicon Valley’, *Architecture and Culture*, pp. 1–21, <https://doi.org/10.1080/20507828.2023.2170118>.

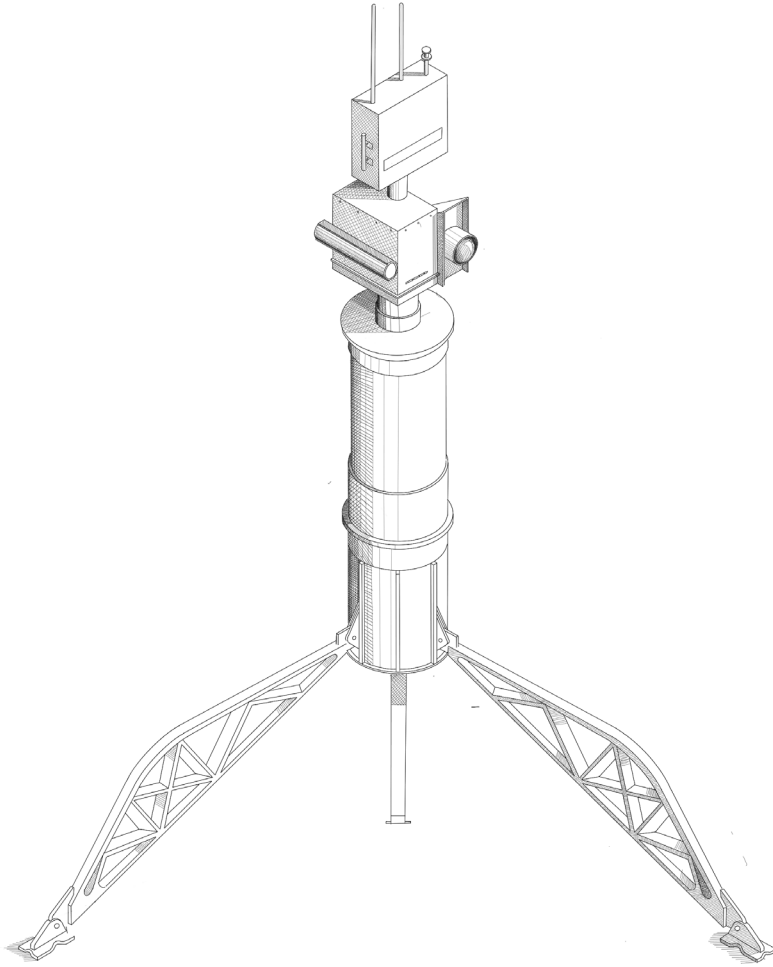

Figure 1 Anduril Sentry. One of the early prototypes of the Sentry developed for the Mexico/US border. Image by author.

11 This piece owes an immense debt of gratitude to Valeria Luiselli. The central thesis here, that the stories of the border can be defined spatially through their east to west, south to north, is explored by Luiselli in her *Lost Children Archive*. She reflects on the way the book challenges the genre of the road novel, which she identifies as central to the myth of the American nation and its expanding border west: 'The book intertwines the foundational myth of the East to West narrative with all these other ways of understanding movement and displacement and relations in this country and in doing so it brings other traditions in storytelling which is not only the American-Anglo tradition of the road novel, but also the Latin-American tradition where the trip or the voyage has a lot to do with descending into consciousness, descending into the underworld.' The theme of the descent to the underworld will be relevant in the second half of this piece, also inspired by the work of Yuri Herrera. See: Valeria Luiselli, 'Lost Children Archive at the Penguin Random House Open Book Event' (New York, 2018), [https://www.youtube.com/watch?v=1auQI_snZUY](https://www.youtube.com/watch?v=1auQI_snZUY;);

Valeria Luiselli, *Lost Children Archive*, trans. by Christina McSweeney (London: Harper Collins, 2019).

12 Image by author redrawn from the original photograph by Gregg Segal for the cover of *Time Magazine*. See: Joel Stein, 'Why Virtual Reality Is About to Change the World,' *Time*, August 2015, <https://time.com/3987022/why-virtual-reality-is-about-to-change-the-world/>.

13 Gregory Renault, 'Science Fiction as Cognitive Estrangement: Darko Suvin and the Marxist Critique of Mass Culture', *Discourse*, 2 (1980), pp. 113-41. Suvin discusses Science Fiction at length in: Darko Suvin, *Metamorphoses of Science Fiction: On the Poetics and History of a Literary Genre* (Oxford: Peter Lang, 2016).

14 John Rieder, *Science Fiction and the Mass Cultural Genre System* (Middletown: Wesleyan University Press, 2017).

TECHNO-FANTASIES

Palmer Luckey is a self-confessed Science Fiction dork, giggly as he recites impromptu lines from the original *Star Trek* and its Holodeck, or how working for the Department of Defence is actually cool and that there is nothing wrong with being a fan of *The Lord of the Rings* and a patriot and wanting your country to be great again.

As a genre, Science Fiction has been notably difficult to define, excluded as it has often been from the formal literary genres. Darko Suvin famously defined it as a genre of ‘cognitive estrangement,’ by which he meant to distinguish it from other forms of speculative fiction which present the familiar in an unfamiliar light, for example Mythology and Fantasy.¹² The creation of alternative universes is linked to a cognitive, or scientific rigour. Suvin’s definition has been seen as problematic in the way it is normative rather than descriptive: it creates an ideal image of what the genre ought to be so it can be included in serious academic studies, rather than on existing SF, the historically situated catalogue of texts associated with the genre.¹³

Existing Science Fiction had been important in crafting the mythologies of Palmer Luckey and, in turn, of the border.¹⁴ Luckey was involved in the 2016 Trump campaign, financing far-right groups to smear Hillary Clinton. However, after a media scandal he was forced to leave Facebook and later he founded Anduril, a company which aims at leveraging consumer technology for the defence sector. The name of the company, Anduril, references the mythological sword in *The Lord of the Rings*, capable of summoning the deadliest army ever to walk the Earth. The first product of the

company was the Anduril Sentry, a mobile observation post meant to provide sensors on the ground to create situational awareness displayed through ‘*Call of Duty* goggles.’ When asked about the motivation for the device, Luckey describes having long conversations with his co-founders in which Science Fiction becomes the common frame of reference. They talk of *The Matrix*, *Star Wars* and then an idea crystallises: they will create a force field for the Mexican border, just like the ones protecting the fleet of *Star Trek*.

Silicon Valley is well-known for its use of Science Fiction as a way of making sense of the technologies it produces, both as an inspiration for its own designers and as a narrative device to communicate with their customers.¹⁵ The relationship between the real and imagined is an important element of the cultures of the Valley, justifying the way it hoards talent and wealth by promising to create technologies that will bring about prosperity and progress. The ability with which Palmer Luckey crafts his personal mythology speaks of the hyper-masculinity of the tech-nerd, used by him and others to obscure the material conditions of inequality buttressing innovation.¹⁶ I have written elsewhere of the way that the interplay of the imagined and the real in the Silicon Valley mythologies connect it to the foundational techno-utopianism which, alongside the cult of domesticity in the nineteenth century, justified the emergence of the United States as a settler colonialist project.¹⁷

15 There is a well-documented link between Silicon Valley and Speculative Fiction. Janeil Page Swarthout looks at the way that new technologies often draw on mythological visions of unity and redemption and that, against the common assumption that technological pursuits are driven by rational enquiry, spiritual pursuits are at the core of Silicon Valley’s identity. See: Janeil Page Swarthout, ‘The Gods of Silicon Valley: Finding Mythological Meanings within the Technologies of the 21st Century’ (unpublished Ph.D., Pacifica Graduate Institute).

16 Emily Crandall, Rachel Brown and John McMahon look at Peter Thiel and Elon Musk, prominent Silicon Valley figures connected to Palmer Luckey, to suggest that the mythologies of Silicon Valley are not innocent allusions and rhetorical devices but instruments to depoliticise the human and material cost of bringing about the utopia involved in the conception of Silicon Valley as the beacon of civilisation-saving innovation. See: Emily K. Crandall, Rachel H. Brown, and John McMahon, ‘Magicians of the Twenty-First Century: Enchantment, Domination, and the Politics of Work in Silicon Valley’, *Theory & Event*, 24.3 (2021), pp. 841–73, <https://doi.org/10.1353/tae.2021.0045>.

17 See Hernan, ‘Of Force Fields’.



Figure 2 (above) Palmer floating away. Palmer Luckey came to prominence with his work crafting the Oculus Rift, a device that 'revolutionised' the games industry by offering a cheaper alternative to cumbersome and expensive Virtual Reality headsets. Image by author. Image by author redrawn from the original photograph by Gregg Segal for the cover of Time Magazine. See: Joel Stein, 'Why Virtual Reality Is About to Change the World,' *Time*, August 2015, <https://time.com/3987022/why-virtual-reality-is-about-to-change-the-world/>.

Figure 3 (below) Palmer Luckey cosplaying as 'Quiet', the heroine in of the videogame Metal Gear Solid V. The costume, with bikini and ripped stockings, was criticised as sexist. In response, the creator Hideo Kajima crafted a backstory to justifying it, saying Quiet was infected with a parasite which requires her to absorb oxygen through her skin. Palmer attended Mashi Asobi in 2017, a Japanese Science Fiction convention, in 2017 cosplaying as Quiet. Image by author redrawn from the news article: James Vincent, 'Palmer Luckey Returns to Public Life Sporting a New Goatee', *The Verge*, 5 May 2017, <https://www.theverge.com/tldr/2017/5/5/15555224/>

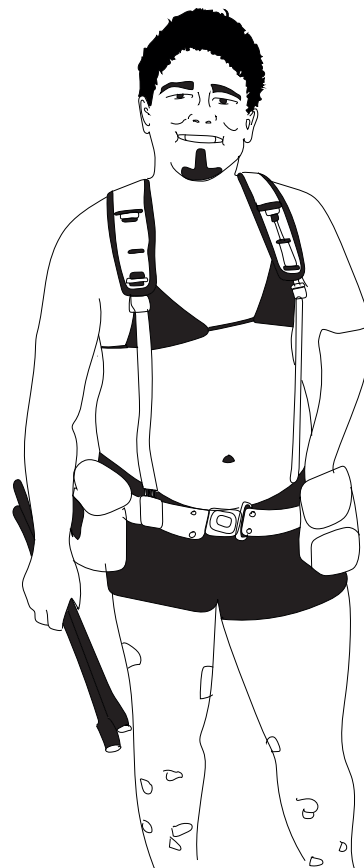

MAGICAL REALISM

It is this tension between the imagined and the real which, paradoxically, creates fruitful parallels to the tradition of Speculative Fiction in Latin America (and the opportunity to re-imagine the new technologies of the border). The term Magical Realism was originally used to describe the post-expressionism of 1920s painting, in which scenes of photographic naturalism were juxtaposed with paradoxical elements that gave them a sense of unreality.¹⁸ It was not until the 1940s when the term became territorialised, acquiring a political valence in Cuban writer Alejo Carpentier's conception of the marvellous real (the 'real maravilloso' in the original) which he linked to Latin American history and politics, where it was 'encountered in its raw state, latent and omnipresent.'¹⁹ Instead of an aesthetic category, the marvellous real signified a political movement and an ethical position, used to resist the historical effects of empire in the region and the very real hegemony that Europe and the United States still exerted in these countries.²⁰

Magical Realism has overlaps with other traditions of speculative fiction. Like Fantasy (and Science Fiction to an extent), Magical Realism is defined by the juxtaposition of the real and the fantastic, which points to 'rationalism turning upon itself'.²¹ Attending to its original meaning in the art criticism of Franz Roh, Magical Realism presents the real in a cold, clinical style while weaving elements that make the familiar seem unfamiliar (an operation which resonates with the cognitive estrangement of Science Fiction as proposed by Suvin).²² It differentiates itself, however, by introducing elements of the fantastic which it makes part of the real and, by doing so, challenges Western literary traditions which exclude the possibility of the supernatural and the magic coexisting with reality. Suzanne Baker suggests that the genre is defined by a dual spatiality of the text, in which two conflicting worldviews are co-present, the logic of the European intellectual tradition and the mysterious, magical (and often assumed irrational) native world system.²³

18 The definition of Magical Realism is disputed and dependent on who formulates it. For contemporary Latin American writers, the term has become a sort of cage, a way of encapsulating the whole of the literary production of the region independent of its formal and thematic concerns (which is rich and varied). The two main definitions are connected to Roh's and to Carpentier's which, although polar opposites on first inspection, suggests that both terms react to violent historical moments. While the term in Latin America became a symbol of resistance to European and American hegemony (and later to the repression of dictatorial regimes), Roh thinks of Magical Realism as a strategy to show "the inextinguishable horrors of our time". See: Kenneth Reeds, 'Magical Realism: A Problem of Definition', *Neophilologus*, 90.2 (2006), pp. 175–96, <https://doi.org/10.1007/s11061-005-4228-z>.

19 The term, however, was used earlier in the same year (1949) by Venezuelan writer Arturo Uslar Pietri who, borrowing the term from a translation of Roh's text published in the literary magazine *Revista de Occidente*, wrote of a 'new creative mode' which considered 'man as a mystery amidst realist data. A sort of poetic divination, or a poetic denial of reality. Something which, for lack of a better term, could be defined as magical realism' (translation author's own). The text in the original Spanish is quoted in: Kenneth Reeds, *Magical Realism*, p. 181.

20 There are multiple interpretations of the definition of Magical Realism and its status as a literary form unique to Latin America, its politics and history. While Carpentier claims it as a political stance against empire, Puerto Rican theorist and critic Angel Flores argues for the universality of the term, finding its precursors in Franz Kafka, Edgar Allan Poe and Herman Melville. For a detailed discussion of the nuances in the Carpentier and Flores definition of Magical Realism, see: Defne Tutan, 'A Hybrid Discourse: From Latin American Magic Realism to the British Postcolonial Postmodern Novel', *Selçuk Üniversitesi Sosyal Bilimler Enstitüsü Dergisi*, 36 (2016), pp. 38–50.

21 Theo D'haen quoted in Tutan, 'A Hybrid Discourse', p. 40.

22 This observation is borrowed from Reeds and his analysis of the relationship between Expressionism and the Magical Realism conceptualised by Roh. He writes: 'magical realism was a return to reality, but not simply going back to the realism which existed before Expressionism — a homecoming which carried with it the baggage from the trip through Expressionism's existential voyage, a mix of wild flights and anchored reality [...] it tried to dissect it, renew it in a cold, clinical style while presenting it in such a way that the normal became familiar.' See Kenneth Reeds, *Magical Realism*, p. 178.

23 Suzanne Baker, 'Binarisms and Duality: Magic Realism and Postcolonialism', ed. by Michèle Drouart, *Span Postcolonial Fictions*, October.36 (1993), pp. 82–87.

The dual spatiality of Magical Realism explains the way it has been theorised in the context of post-colonialism. When Carpentier argued that in Latin America the 'strange is always commonplace' he was reflecting on a sense of alienation felt by many in the region and across the Global South where 'reality is imposed from the outside', which requires reality to be inverted and deconstructed 'to substitute their own vision.'²⁴ Magical Realism is located in Latin America, with its specific history of repression, violence and waves of Spanish, Portuguese, French, British and Dutch colonisation, but it also extends to authors in other regions coming to terms with the legacies and ongoing processes of colonisation.²⁵ It thus operates as a challenge to the Enlightenment and the associated project of European colonialism, becoming an 'oppositional instrument, overtly critical of imperial and colonialist politics' which 'seeks to subvert colonial cultural hierarchies "by revaluing the alternative, non-Western systems of thought, presenting them as a corrective or supplement to the dominant world view".'²⁶

Understanding Magical Realism as a response to post-colonial geographies, in the plural rather than as a regional movement, enables connections with other traditions of imagining. José David Saldivar contextualises Magical Realism in post-modernist

literature, which brings the genre close to the notion of fabulation, defined by Robert Scholes as a departure from 'direct representation of the surface of reality' paired with a reengagement of reality 'by way of ethically controlled fantasy.'²⁷ Although Scholes highlights the playful aspects involved in the term of fabulation, the act is meant as 'an attempt to find more subtle correspondences between the reality which is fiction and the fiction which is reality.'²⁸ Fabulation suggests also a reaching out beyond formal narrative and into the everyday practices of storytelling as a way of making sense of the world. In a more contemporary theorisation of the term, Donna Haraway chooses to speak of Speculative Fabulations, partly as a word play on Science Fiction but also as an invitation for a more diverse coming together of disciplines and traditions (Speculative Feminism, Speculative Fantasy) as well as the everyday practices of storytelling and worlding. For Haraway, the fable is a creative place to explore facts that do not hold still and that give way to new possibilities.²⁹

23 Suzanne Baker, 'Binarisms and Duality: Magic Realism and Postcolonialism', ed. by Michèle Drouart, *Span Postcolonial Fictions*, October.36 (1993), pp. 82–87.

24 See Tutan, 'A Hybrid', p. 42.

25 The term of Magical Realism is much devalued in contemporary Latin America, scorned by many writers given the way it has been used historically to exoticise and simplify the literary output of a whole region (making it more palatable and attractive to the translation market). Maria Takolander suggests that despite the problematic beginnings and evolution of the genre, it is still a valuable device to speak of minority experiences. She suggests that the irony that permeates Magical Realist texts make them an ideal vehicle to examine 'the spectral nature of the fake and of the real.' See: Maria Takolander, 'Magical Realism and Fakery: After Carpentier's "Marvelous Real" and Mudrooroo's "Maban Reality"', *Antipodes*, 24.2 (2010), pp. 165–71.

26 The quote is from Jesús Benito, Ana Manzanás and Begoña Simal who write their definition of Magical Realism as a postcolonial genre interwoven with that of Elleke Boehmer. See: Jesús Benito, Ana M. Manzanás, and Begoña Simal, 'Juxtaposed Realities: Magical Realism and/as Postcolonial Experience', in *Uncertain Mirrors* (Brill, 2009), p. 107; Elleke Boehmer, *Colonial and Postcolonial Literature: Migrant Metaphors*, OPUS (Oxford: University Press, 1995).

27 Robert Scholes, *Fabulation and Metafiction* (Urbana: University of Illinois Press, 1979), pp. 4–8.

28 In drawing the relationship between Postmodernism, Magical Realism and Fabulation I am following the argument made by Defne Ersin Tutan, who has developed an exhaustive review of Magical Realism as post-colonial literature. The quotes come from Scholes. See: Tutan, 'A Hybrid Discourse', pp. 38–50; Scholes, *Fabulation*.

FICTO-CRITICAL APPROACHES

I use the term ficto-critical in reference to the work of others who experiment with fictional registers to overcome the limitations of critical theory. An endless permutation of terms used as adjective and noun, Critical Fiction, Criticism Fiction, Fictional Critical, suggests how different authors might incorporate fiction as a way of producing different kinds of critical writing.³⁰ Jane Rendell uses a ficto-critical approach to bring subjectivities to bear on the way that sites are understood.³¹ Hélène Frichot has used the combination to explore the colonial pasts and their enduring presents in tourism.³² Emma Cheatele uses fiction to give voice to women and minorities who have been underrepresented in history and lost.³³ Naomi Stead has explored the way that words construct architectural worlds, as well as how different cultures, queer, lesbian, gay, are represented in these.³⁴

In developing my own ficto-critical approach, I am interested in the way that Magical Realism can enable ways of exploring the textures of the real. I use fictional writing as a way of applying a corrective lens which, to paraphrase Barbara Godard, helps us in seeing through the fiction we have been convinced to take for the real and imagine ways of decentering

technology and the hold tech-bros have over our imaginations of the future.³⁵ Saldivar suggests that Magical Realism operates by superimposing one reality on another, making way for a different politics of the possible and, inspired by this, I create accounts which superimpose fiction over the real-life Palmer Luckey.³⁶ The process is fragmentary, using three short fictions as critical prompts which, themselves, are a transmutation, shifting strategies and devices from Science Fiction, predominant north of the border, to the fantastical and fable, more at home in the south. This juxtaposition and splicing are meant to detect potentialities in the present and pull on the threads involved in the way that technology forces us to imagine the future of the border.

29 In describing facts that won't hold still, Haraway uses the term of wild facts from Martha Kenney. See: Martha Kenney, 'Anthropocene, Capitalocene, Chthulhocene', *Art in the Anthropocene: Encounters among Aesthetics, Politics, Environments and Epistemologies*, 2015, pp. 255–70; Donna J. Haraway, *Staying with the Trouble: Making Kin in the Chthulucene* (Durham: Duke University Press, 2016).

30 Jane Rendell, 'Prelude: The Ways in Which We Write,' in *Writing Architectures: Ficto-Critical Approaches*, ed. by Hélène Frichot and Naomi Stead, (London: Bloomsbury, 2020), pp. 1–10.

31 Jane Rendell, *Site-Writing: The Architecture of Art Criticism* (London: Bloomsbury, 2011).

32 Hélène Frichot, 'Impossible Constructions of an Island Paradise', in *Writing Architectures: Ficto-Critical Approaches*, ed. by Hélène Frichot and Naomi Stead, (London: Bloomsbury, 2020), pp. 47–59.

33 Emma Cheatele, 'Writing Architectures: Ficto-Critical Routes through Eighteenth-Century London', in *Writing Architectures: Ficto-Critical Approaches*, ed. by Hélène Frichot and Naomi Stead (London: Bloomsbury, 2020); Emma Cheatele, *Part-Architecture The Maison de Verre, Duchamp, Domesticity and Desire in 1930s Paris* (London: Routledge, 2017).

34 Naomi Stead, *Semi-Detached: Writing, Representation and Criticism in Architecture* (Melbourne: Uro Media, 2012).

35 Barbara Godard quoted in Rendell, 'Prelude', p. 4.

36 José David Saldivar, 'Postmodern Realism', in *The Columbia History of the American Novel*, ed. by Emory Elliott and Cathy N. Davidson (New York: Columbia University Press, 1991).

DRESSING UP

Palmer takes the stage. He wears denim trousers, too long, but doesn't roll them. They fall long over naked ankles and leather flip flops. The blue shirt is untucked, top button undone and wide collar carefully spread over the lapels of an oversized jacket, cuffs slipping into his thumbs. He looks like a kid Halloween-dressing as Tony Montana. He paces around the stage, speaks in a monotone voice as he tries to remember his lines. He loses his breath, draws air as quick as he can – his sentences come in a flurry. His throat dries up; he smacks and clicks like a metronome. He rambles and breaks up his soliloquies with long pauses. He loses his place, gesticulates, closes his eyes and tries to remember the sequence of ideas. He looks around in panic, pleading for help. He looks confused. He rolls his sleeves and knocks the air once, twice, three times, see if that brings the idea back. It doesn't. He squints and looks at the monitor – 'I'm a little short-sighted so right before this I realised, I couldn't read all my notes,' he belches and trails off and back into his speech.

Deep breath, closes his eyes again. 'Okay, this is my first time in a Defence conference, and it's been so awesome to come and speak to all of you guys and see how we can do something cool and awesome together.' He knows he is rushing, he slows down and squints once again to read his notes in the prompter. 'So, I'm super passionate about Artificial Intelligence and what it can do for you guys. I am a patriot and I want the Sentry to be the force field to defend this great nation. We've done some progress there and I'm super proud of what we did but let's be honest, right now, it's a dumb force field, bunch of sensors and we can detect someone crossing the border. Kid's play, booring!'

The audience smirks and the stars in the lapels catch the light. He has them, they're hooked. "What you need is a smart force field. Look, it's easy, the problem that you have is not detecting when someone crosses the border. You want to know when the wrong sort of people crosses it. I know, the people at Legal asked me to say I'm not racist but let's face it, not everyone belongs in this country!"

'So AI is very early, we're just seeing the tip of the iceberg of what is possible. ChatGPT, Midjourney, very exciting and cool but we're ready to do things that we're not able to do with any other technology. That's why I've been working on an AI to detect illegals. It's very simple — we can all be reduced to a pile of information, from the trail we leave when we look up stuff online to the phone numbers we call. Put it all together and it's a fatberg of nonsense. But feed it to the AI and it can tell you exactly who you are, your age, gender, education. And this is where it gets very exciting. There's some awesome stuff coming out of sound analysis — we listen to the people crossing and we can tell you, with a really high rate of precision, where they come from. We analyse the language they speak, the accent, but we also pick up on the small details, the clothes they use, the sound that cheap fabrics make when they walk, how fast, how nervous they are when they cross. All of this stuff leaves something I call the "Alien Signature". Put that on a Sentry and you have an intelligent force field. It zooms into wetbacks and blocks them.³⁷

'Think of all the money you spend in passports, visas, and border agents checking them. That's the past, you don't need that anymore. How cool is that?' Standing ovation. Palmer smiles. He's made a killing.

37 Although Artificial Intelligence speech recognition has not been integrated in the Anduril Sentry yet, the technology has been used in the European border. As Pedro Oliveira argues, efforts to detect 'migrant' bodies date back to the use of human linguists, a practice that raised ethical concerns over accuracy. Artificial Intelligence has provided a false sense of reliability and precision, to a deeply flawed, racist idea. See: Pedro Oliveira, 'To Become Undone', *DING Magazine*, 2021, <https://dingdingding.org/issue-4/to-become-undone/>.

Figure 4 Palmer and his Sentry, listening for trouble. Image by author.

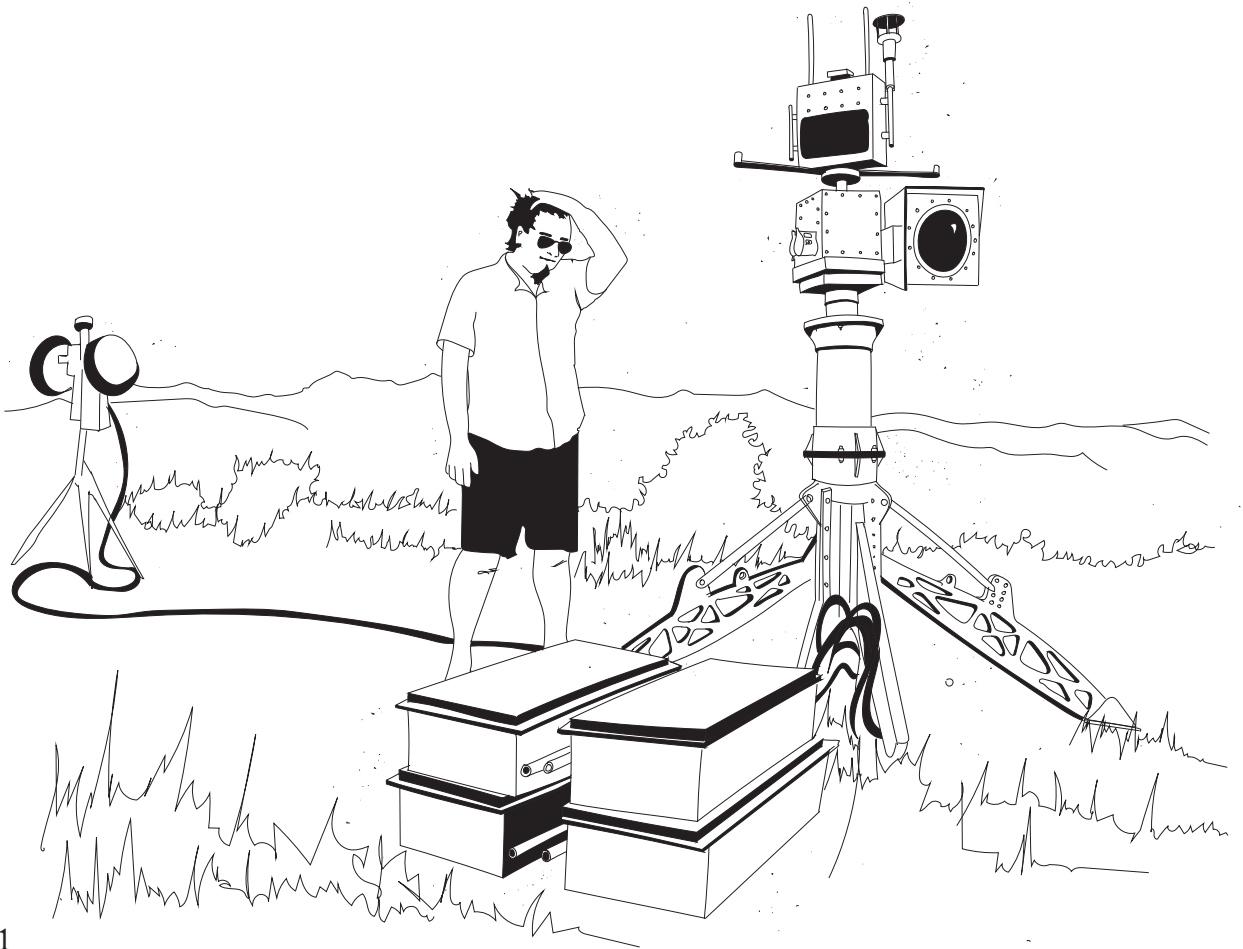

Edward Said suggests that the ideas sustaining colonisation are threaded throughout the cultural production of empires. The connection is nowhere as evident as it is in the emergence of the novel in the nineteenth century, 'a cultural artefact of bourgeois society' that is closely interwoven in the fabric of imperialism to the point they are 'unthinkable without each other.'³⁸ Rieder expands the argument to suggest the same is true of Science Fiction, with its tropes and narratives deeply interwoven with those of empire.³⁹ The Anduril Sentry is imagined as a technology of ordering and control in its reference to *Star Trek*'s force fields, which protect the intergalactic ships that explore and expand the Empire. It is a technology which embodies the principles of hierarchy and othering that sustain imperial and colonising projects, making sense of who belongs and who does not.

But it is also our narratives of technology that are laced with colonialism. The Silicon Valley credo beatifies the self-made genius who wrestles and slays the dragon of bloated, stifled economies; Steve Jobs for Apple, Mark Zuckerberg for Facebook, Jeff Bezos for Amazon, Elon Musk for Tesla, Larry Page and

Sergey Brin for Google.⁴⁰ The way we think of the technoscience complex suffers from what the writers Ada Palmer and Jo Walton terms as *protagonismo*: the assumption that one person, a white, wealthy man, can 'save the day, make the difference, solve the problem and change everything.'⁴¹ As an antidote, Malka Older suggests speculative resistance, using the power of speculative fiction to explore alternative ways in which society might be organised.⁴² Speculative resistance goes against the tales of heroic men to imagine, for example, the power of collectives to destabilise.

38 Edward W. Said, *Culture and Imperialism* (Random House, 2014), pp. 70-71.

39 Rieder, *Colonialism and the Emergence*, pp. 1-2.

40 Richard Tutton, 'Sociotechnical Imaginaries and Techno-Optimism: Examining Outer Space Utopias of Silicon Valley', *Science as Culture* 30, no. 3 (3 July 2021): pp. 416-39, <https://doi.org/10.1080/09505431.2020.1841151>.

41 Ada Palmer and Jo Walton, 'The Protagonist Problem', *Uncanny, A Magazine of Science Fiction and Fantasy*, June 1, 2021, <https://www.uncannymagazine.com/article/the-protagonist-problem/>.

42 Anke Schwarz, 'Practice Believing That the World Can Change Radically': Interview with Malka Older,' *Latin American Futures*, 9.1 (2021), pp. 27-32.

CATEGORIES OF EXCLUSION

WIRED magazine, March 2028

The idea was simple enough. When Palmer proposed to detect the ‘alien signature’, his idea was to combine all sorts of metrics to determine someone’s nationality. And it worked, for a while. The DOD described the prototype as a ‘resounding success’ and it was soon rolled into mass production to create the ‘United States Force Field’. Then we learned the AI was having trouble placing people in just two categories, so the last time the company released a statement they had evolved the model to allow a list of 56 other options which placed anyone in a spectrum, from ‘full-blooded, honest-to-God’ American to ‘frijolero’. After being accused, once again, of structural racism, the company stopped discussing the model in public.

Now we know why. The cyber-activist group ‘Los Hijos de Aztlán/Aztlán Brood’ began to quietly feed the model with inconsistencies and paradoxes, or what they called as the ‘sounds of the new people’. They would, for example, feed the AI with the sound of a Missourian man listening to 3,459 hours of underground psychedelic cumbia while writing recipes for 385 variations of salsa verde in one year. Then they started their campaign of ‘poetic performance’, with activists on both sides of the border “assimilating” each other’s gait and posture and gestures. At the height of evocative brilliance, a Sinaloan woman walked the land stretch of the Mexico-United States border reciting the lines of all of Quentin Tarantino’s movies. ‘And do you know what they call a Quarter Pounder with cheese in Paris?’

AI researchers believe the system must have collapsed at some point in the last three weeks, overwhelmed by ever-expanding categories and fractal branching. A specialist in AI ethics interviewed for this piece suggested a different scenario. AI systems are said to ‘hallucinate’ when the wrong data set is fed to them and, as a result, begin to spit nonsensical answers to queries. She believes, however, that systems hallucinate when there is a logical, or moral fallacy, in the original model. ‘Maybe it was never possible to categorise people, maybe we were never meant to keep them apart.’

The DOD was contacted for comment.

Gloria Anzaldúa defines the Mexico-US border as the place where the first world grates against the third. It is also the place where different projects of colonisation, the British and Spanish Empire, collide and overlap but coincide in their foundational 'humanism'. As Rosi Braidotti reminds us, the human is a category that indexes exclusions, a hierarchical system that sexualises, racialises and naturalises others.⁴³ The Spanish colonial project depended on a principle of 'puridad de sangre', blood purity, which ensured peninsular Spaniards kept control of the colonies in the American continent and considered the non-Christian natives as less-than-human subjects with no right to land possession.⁴⁴ The settler colonialism of the United States relied on a similar strategy of voiding the rights of Native Americans to the land, which gave white settlers undisputed rights. The involvement of Silicon Valley in border technologies follows a well-documented form of 'digital colonialism' in which corporations extract value

from the Global South and keep a clear demarcation with the North.⁴⁵ These materialities are joined by rhetoric in the United States media, in which migrant bodies are considered less human and out of place, in need of removal.⁴⁶ The commonality of being othered suggests forms of solidarity between technology and those who are still not considered fully human.

43 Rosi Braidotti, *Posthuman Knowledge* (Cambridge: Wiley, 2019).

44 Maria Elena Martinez, *Genealogical Fictions: Limpieza de Sangre, Religion, and Gender in Colonial Mexico* (Stanford: Stanford University Press, 2008).

45 Michael Kwet, 'Digital Colonialism: US Empire and the New Imperialism in the Global South', *Race & Class*, 60.4 (2019), pp. 3–26, doi.org/10.1177/0306396818823172.

46 Otto Santa Ana, "'Like an Animal I Was Treated': Anti-Immigrant Metaphor in US Public Discourse', *Discourse & Society* 10, no. 2 (1 April 1999): pp. 191–224, doi:10.1177/0957926599010002004.

STORIES OF THE BORDER

It's the eternal return. Aztlán is to the North, pass the field of Silent Totems. Con nuestros pasos volvemos sobre los de nuestros ancestros, we walk back on their steps. Tihueque, tihueque, the land of herons awaits. We walk over the steel footprints of The Beast, tracing the journey of the 12,000 who gave their hearts to keep Huitzilopochtli alive.⁴⁷ The slow trundle of metal and joy and screams of the elders. The hands of the women who brought food and the hands of the men who pulled them to the ground. Tihueque, tihueque. We walk in silence, remembering, in communion.

We walk in silence until we see the Silent Totems and then we scream and we sing and we talk in the thousand tongues of our peoples. The Silent Totems listen to us, impassive, their whirring and humming waiting for us.

It is said that the people of the desert attained such perfection in the Art of Cartography that they drew maps of minute detail and in time, the maps thought for themselves and knew of people of a thousand tongues and hundred skins.⁴⁸ The totems fell silent and dreamt us, and then they were left to the inclemencies of the sun. Tattered ruins of a rational time. The people of the desert thought the totems useless and perished.

Tihueque, tihueque, Aztlán is near. We touch the metal skin of the Totems and then each other's and say, we are the New People. Somos la Nueva Gente y estas son las historias con las que hacemos mundos. Worlds are made with these stories.

The border is a fertile ground for mythologies, imagined on both sides of the division line. The idea of the border as a line that separates the civilised world from wilderness has been historically fundamental to the construction of American identity and the elusive but powerful story of the American Dream.⁴⁹ The historian Frederick Jackson Turner, for example, suggested that the frontier line came to define the American nation in the nineteenth century, creating a character distinct from the European nations, that championed democracy and egalitarianism.⁵⁰ The idea of an American Frontierism reinforces the dogma of Manifest Destiny, which made white Americans into a divinely ordained race destined to rule over the continent and bring civilization to the savage natives.⁵¹ The border is, to this day, narrated as a line that separates civilisation from wilderness, as found in 'narco-porn' literature, Hollywood neo-Westerns and news coverage that describes the border as out of control.

Despite its apparent solidity, it is important to point out that the idea of the border as an impenetrable barrier is a relatively recent invention, and that counter mythologies have long suggested a porous membrane rather than a hard demarcation. The poetry of Facundo Bernal, for example, reminds us of 'a time, before fences, walls, and the Border Patrol,

when the border existed to be crossed'.⁵² Bernal was born in Hermosillo, a border city in the Mexican northern state of Sonora, but became an influential voice documenting the emergence of a hybrid people, the pocho community, whose constantly shifting identity and dynamic language speaks of the inter-connection of communities at the borderland.⁵³

Crossing the border is a transmutation. A descent into the underworld, not in the Christian understanding of a place of torment, but closer to the depiction of Mictlān, the deepest region of the Mexica underworld. Yuri Herrera explores the act of crossing the border in *Signs Preceding the End of the World*, a novel which tells the story of a young woman, Makina, who crosses to the United States to find his estranged brother.⁵⁴ Despite the fact that the story is shared by countless Mexicans, Herrera tells the story in a mythological register, using the motif of the underworld to signify the transformation involved in the act of crossing the border; as Makina discovers, her brother has adopted an American identity and become a decorated soldier, making his return to his homeland impossible. Cordelia Barrera suggests that this 'mythic mode' is a strategy to break the acknowledged order of everyday reality and to create an awareness of the 'minority, ethnic and

47 Tihueque is Náhuatl for 'now let us go' and the title to a poem written by Gloria Anzaldúa about her experience teaching in the south Texas public system: Gloria Anzaldúa and AnaLouise Keating, (eds.), 'Tihueque', in *The Gloria Anzaldúa Reader* (Durham: Duke University Press, 2009), pp. 3-4 doi: 10.1215/9780822391272-002.

48 A playful paraphrasing of Jorge Luis Borges' *On Exactitude in Science*. Jorge Luis Borges, *A Universal History of Infamy*, trans. by Norman Thomas Di Giovanni (Harmondsworth: Penguin, 1975).

49 In describing the way that the sense of the domestic was crucial in the articulation of the American nation in the nineteenth century, Amy Kaplan suggests that 'a sense of the foreign is necessary to erect the boundaries that enclose the nation as home.' See: Amy Kaplan, 'Manifest Domesticity', *American Literature*, 70.3 (1998), pp. 581-606, doi: 10.2307/2902710.

50 Heike Paul, 'Agrarianism, Expansionism, and the Myth of the American West', in *The Myths That Made America, An Introduction to American Studies* (Transcript Verlag, 2014), pp. 311-66, <https://www.jstor.org/stable/j.ctvrvxsdq.10> [accessed 1 December 2023].

51 Reginald Horsman, *Race and Manifest Destiny: The Origins of American Racial Anglo-Saxonism* (Cambridge, Massachusetts: Harvard University Press, 1981).

52 Josh Kun, "'Defending What's Rightly Ours': An Introduction to Facundo Bernal's Forgotten Masterpiece of Los Angeles Literature", in *A Stab in the Dark* (Los Angeles: LARB, 2019), p. xviii.

postcolonial' histories which are made invisible by a 'rigid, inflexible reality in which individuals have been stripped of history and indigenous identity.'⁵⁵

The underworld is also used in *Lost Children Archive*, Luiselli's novel which critiques the spatial mythology of the United States and the way it enables ideas of sovereignty and border delineation. As Luiselli discusses, the United States is often narrated as the territorial expansion and colonisation that moves from East to West and which manifests itself in the road trip novel as a form of 'acrossness' which, in its insidiousness, silences the other foundational myths of the country, such as the Hispanic presence that suggests a movement from South to North.⁵⁶ In giving visibility to the other stories that make up the United States, Luiselli seeks to invoke the Latin-American literary tradition in which a voyage is codified as a descent into consciousness and the underworld. The exploration of the horizontal and vertical echoes Anzaldúa, who suggested the movement up north not as an invasion but the eternal return to Aztlán, the mythical place from which Aztec people were said to originate.⁵⁷ Crossing the border is not only a physical act of moving from one territory to another, but an act of translation and a constant toing and froing between two cultures and identities.

CONCLUSION

Anzaldúa tells us the border is where the first world grates against the third and bleeds. It is also where two projects of colonisation meet and where two forms of imagining the future, Science Fiction and Magical Realism, mingle and contaminate each other. In this paper I have analysed how the new technologies of the border are inspired and narrated through mythologies which ignore and make invisible the South to North movements that have been foundational to the United States, and instead highlight an expansion of East to West. To cross the border is a transmigration, a change of state which for many involves a symbolic movement from a darker to a lighter shade of skin. I mirror this transition in the shift from one imagination of the future, predicated by technology as the answer to create a utopian space, to another, which enables different mythologies to co-exist in the text.

Stories are crucial in the construction of the self and the sense of identity. Paul Ricoeur argues that storytelling is crucial in making sense of the world and Donna Haraway invites a practice of fabling, full of wild facts and animals, as the key to create liveable futures.⁵⁸ The fundamental role of storying in locating ourselves in relation to the past, present

53 Bernal was influenced by modernist poets such as Ruben Darío Gutiérrez Najera and Amado Nervo. Unlike them, his verse was decisively 'low-brow', written to be published in the popular press. Anthony Seidman, the translator for the Los Angeles Review of Books' edition of *A Stab in the Dark*, reflects on Bernal's technique saying his prosody was already becoming passé but showed exceptional dexterity in incorporating popular dichos and Mexican slang. See: Facundo Bernal, *A Stab in the Dark* (Los Angeles: LARB, 2019).

54 Yuri Herrera, *Signs Preceding the End of the World* (Sheffield: & Other Stories, 2015).

55 Cordelia E. Barrera, 'Utopic Dreaming on the Borderlands: An Anzaldúan Reading of Yuri Herrera's *Signs Preceding the End of the World*', *Utopian Studies*, 31.3 (2020), pp. 475–93. (p. 481), doi:10.5325/utopianstudies.31.3.0475.

56 Luiselli describes the novel in terms that it seeks to destabilise the genre of the American road trip novel as a way of making visible the other stories that are made invisible. See Luiselli, 'Lost Children Archive at the Penguin Random House Open Book Event'.

57 Gloria Anzaldúa, *Borderlands: The New Mestiza* (San Francisco: Aunt Lute Books, 2012).

58 Paul Ricoeur, 'The Function of Fiction in Shaping Reality', *Man and World*, 12.2 (1979), pp. 123–41, doi:10.1007/BF01252461; Donna Haraway, *SF: Speculative Fabulation and String Figures* (Kassel: Hatje Cantz, 2011).

and future explains the appeal that mythologies, especially self-mythologies, hold for Silicon Valley. It also explains the potential of these mythologies to shape architectural spaces. As I write elsewhere, tropes and storylines borrowed from Science Fiction and Fantasy increasingly shape our expectations of what it means to be at home, the gendered roles within it, and the relation to new devices meant to 'serve' us.⁵⁹ The new technologies of the border are narrated in the register of technological utopia, offering a safer world to those who are lucky enough to be inside its boundaries but as Elizabeth Grosz suggests, utopias are often a reflection of the past masquerading as the future, which makes the narrative of the past a crucial and political act.⁶⁰

The use of Science Fiction and Fantasy enables a partial and selective memory of the borderlands which excludes racialised bodies and their stories of movement, which have also defined the land. To story the border, and to welcome the dual spatiality and ambiguity of Magical Realism, is a political act to shape the politics of the possible – not making improbable technologies like force fields believable

but enabling the multiple memories of the land to exist, with its encounters and multiplicity. Despite the current political climate, which reduces the crossing as an economic and often criminal act, the move from South to North is laden with a history of exchange that is central to the formation of the United States and of Mexico itself.

59 Luis Hernan and Carolina Ramirez-Figueroa, 'Time Is out of Joint: Digital Domesticity and Magical Realism', *Journal of Architectural Education*, 75.2 (2021), pp. 184–91, <https://doi.org/10.1080/10464883.2021.1947672>; Luis Hernan and Carolina Ramirez-Figueroa, 'A Home with a Future. Digital Domesticity and the Vague Fictions of Silicon Valley', *Architecture and Culture*, pp. 1–21, doi.org/10.1080/20507828.2023.2170118.

60 Utopia is, in the words of Elizabeth Grosz, the enactment of ideals of a privileged few which, paradoxically, offers no future at all but the pretence of the past in the trappings of tomorrow. See: Elizabeth Grosz, *Architecture from the Outside: Essays on Virtual and Real Space*, Writing Architecture Series (Cambridge: MIT Press, 2001).

AUTHOR BIOGRAPHY

Luis Hernan

Luis is Lecturer in Spatial Narratives at the School of Architecture, University of Sheffield where he is also deputy director of the Postgraduate Research and director of the PhD by Design programme.

His research explores the interface between stories, narrative and architecture. Inspired by the Latin-American literary tradition, Luis' work springs from stories as central to the way that we inhabit and make sense of architecture and urban space. He is particularly interested in the political, social and spatial aspects of the future, examining how ideas of progress, modernity and utopia have come to shape the imaginaries of buildings and cities, interfacing as well with the production of nostalgia and desire in late-stage capitalism. He explores the notion of futures in the domestic space and in the articulation of the Mexico-United States border, a process which has strengthened my interest in the logic of Empire and colonialism. This trajectory has evolved in an interest in the past and lost futures in the North of England, looking at the way that de-industrialisation has been narrated by local communities and intertwined with the processes of extraction and exploitation by Empire.

Luis' research is transdisciplinary, combining critical theory with creative practice. Parallel to his career as a critical writer and researcher, Luis also practices as photographer, poet and fiction writer. He is involved in a wide range of initiatives including the SSoA Feminist Library and the Architectural Network for Decolonising (AND).

